

# Enhanced Virtual Synchronous Generator Control Strategy for Thermoelectric Generation System

Feng Ji <sup>1\*</sup>, John Xu <sup>1</sup>

<sup>1</sup> Faculty of Science and Engineering, University of Nottingham Ningbo China

## ABSTRACT

The virtual synchronous generator (VSG) control strategy is beneficial to improve the damping characteristics of the system. However, the traditional VSG control method based on droop characteristics can lead to static frequency deviation for the frequency modulation. A kind of enhanced VSG control strategy is described in detail in this paper. The static frequency deviation can be eliminated and the secondary frequency modulation can be realized within 0.5 seconds. A Matlab model is used to simulate the operation of working load fluctuation under isolated island operation mode. The simulation result shows that the design is feasible.

**Keywords:** Enhanced Virtual Synchronous Generator, Thermoelectric Generator System, Distributed Power System, Frequency Stability

## 1. INTRODUCTION

As shown in the Fig1, there are two operation modes for the thermoelectric generator system (TGS) which are grid on and grid off. In the grid-on operation mode, the frequency is supported by the electric grid. And there is no need to adjust the frequency of the distributed power system by the TGS. In the grid-off operation mode, the frequency of the distributed power system is very sensitive to the fluctuation of working load. In addition, the frequency fluctuation will affect the stable operation of working load and the thermoelectric equipment. Many kinds of working load are frequency sensitive. A large frequency changing range will seriously affect the normal operation. So how to maintain the frequency stability is one of the key control strategies for the distributed power system. The voltage stability of the power system also faces with similar situation [1-2].

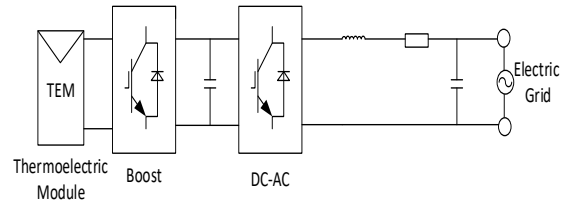

Fig 1 Basic structure of TGS connected to electric grid.

Since the inverter of TGS does not possess the rotational inertia, the inertia of the AC-DC hybrid system will be reduced. And the frequency deviation and oscillation may occur when the electric grid is disturbed. The VSG technology can be applied to overcome such shortcomings. The grid-connected inverter can similarly as the synchronous generator in operation mechanism by simulating the active frequency modulation and reactive voltage modulation [3-4].

As shown in the Fig 2, the synchronous generator operates at the frequency  $f_a$  at the initial time. The active power of the synchronous generator is  $P_a$ .

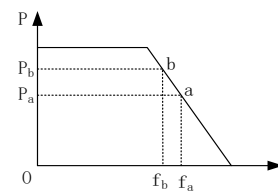

Fig 2 Static characteristic curve of power and frequency for synchronous generator.

When the active power increases, the speed of the synchronous generator decreases. And the frequency drops to  $f_b$ . The output active power of the generator increases to  $P_b$  through the governor regulation. Then the active power of the power system is balanced. And the generator works at the point B. In this process, the frequency decreases  $\Delta f$  and the output active power increases  $\Delta P$ . The ratio of active power variation to

frequency variation can be expressed by the slope of power frequency characteristic curve as the equation (1).

$$K\alpha = \frac{f_a - f_b}{P_a - P_b} \quad (1)$$

In the equation (1),  $K\alpha$  is the adjustment coefficient of the synchronous generator. And it can be observed that the frequency and power have the opposite changing trend. However, the traditional VSG control method based on droop characteristics will produce static frequency deviation during frequency modulation. Therefore, an enhanced VSG which can eliminate static frequency deviation will be introduced in this paper.

## 2. MODELING OF ENHANCED VSG

### 2.1 Schematic Diagram of VSG

Because synchronous generator has the advantages of large inertia and output impedance, it is friendly to the power grid. The excitation control and frequency control algorithm of the synchronous generator can be applied to the inverter of TGS. It can simulate the frequency and voltage output characters of synchronous generator and improve the frequency and voltage stability of AC power system. The schematic diagram is shown in the Fig 3.

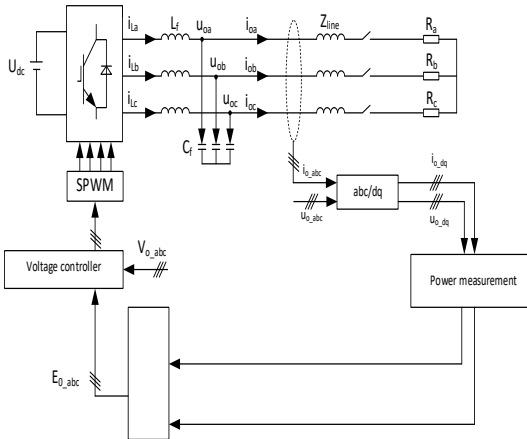

Fig 3 Schematic diagram of VSG.

The values of AC outlet voltage  $U_a$ ,  $U_b$ ,  $U_c$  and current  $I_a$ ,  $I_b$ ,  $I_c$  are obtained by sampling. After corresponding d-q transformation, the working load power can be calculated by the equation (2), (3) and (4).

$$U_{dq0} = \frac{2}{3} \begin{bmatrix} \cos \theta & \cos(\theta - 120^\circ) & \cos(\theta + 120^\circ) \\ -\sin \theta & -\sin(\theta - 120^\circ) & -\sin(\theta + 120^\circ) \\ \frac{1}{2} & \frac{1}{2} & \frac{1}{2} \end{bmatrix} \begin{bmatrix} U_a \\ U_b \\ U_c \end{bmatrix} \quad (2)$$

$$I_{dq0} = \frac{2}{3} \begin{bmatrix} \cos \theta & \cos(\theta - 120^\circ) & \cos(\theta + 120^\circ) \\ -\sin \theta & -\sin(\theta - 120^\circ) & -\sin(\theta + 120^\circ) \\ \frac{1}{2} & \frac{1}{2} & \frac{1}{2} \end{bmatrix} \begin{bmatrix} I_a \\ I_b \\ I_c \end{bmatrix} \quad (3)$$

$$\begin{cases} P_e = U_d I_d + U_q I_q \\ Q_e = U_q I_d + U_d I_q \end{cases} \quad (4)$$

### 2.2 Control Algorithm Model of Enhanced VSG

When the working load of VSG changes, the power balance is broken. The operating parameters of the inverter will also change. And the controller will adjust accordingly. The adjustment process will be delayed because of the inertia of the synchronous generator. Therefore, the output power will not follow the working load changes instantaneously [5-6]. The rotor motion equation of the enhanced VSG is shown as equation (5).

$$\begin{cases} J\omega \frac{d\Delta\omega}{dt} = P_t - P_e \\ \Delta\omega = \omega - \omega_n \\ \frac{d\delta}{dt} = \omega \end{cases} \quad (5)$$

J is the moment of inertia of the synchronous generator.  $\omega_n$  is the grid synchronous angular speed.  $\omega$  is the actual angular speed.  $P_t$  and  $P_e$  are mechanical power and electromagnetic power.  $\delta$  is the generator power angle. The existence of the moment of inertia J is the most important difference between VSG and traditional inverter. When the synchronous generator is running, the existence of the moment of inertia makes the rotor store a part of the energy. Therefore, the system has a slow dynamic characteristic which can effectively suppress the rapid change of frequency and power oscillation. The control block diagram of the enhanced VSG is shown in the Fig 4 Model of the enhanced VSG control algorithm.

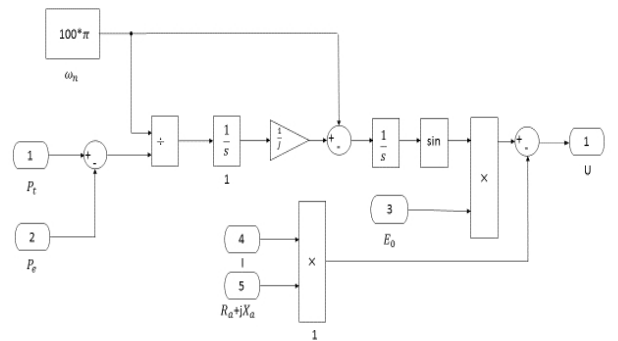

Fig 4 Model of the enhanced VSG control algorithm.

### 2.3 Design of Power and Frequency Controller

In the synchronous generator system, the system needs to be equipped with a governor and excitation control system to work. And the VSG also needs to be equipped with a control system similar to the synchronous generator. The schematic diagram of VSG governor and excitation control system will be obtained according to the characteristics of synchronous generator. Furthermore, the active control loop and reactive control loop of VSG are modeled and designed respectively. The mechanical power provided by the prime mover is always equal to the electromagnetic power consumed by the working load. The fluctuation of working load will lead to the imbalance of power supply and demand which will cause the frequency deviation. At this point, the generator can adjust the output by changing the steam intake. Then the power balance can be re-established. This process is primary frequency modulation of the power system.

As shown in the equation (6), the relationship between the variation of active power and the variation of frequency is listed.

$$\Delta P = \Delta f \left( K_p + \frac{K_I}{S} + K_D S \right) \quad (6)$$

Therefore, the active power and frequency controller are shown as Fig 5.

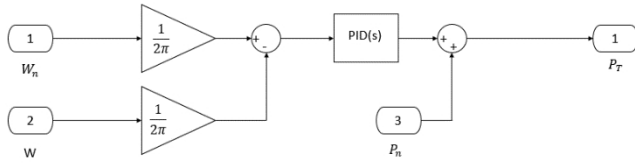

Fig 5 Power and frequency controller.

#### 2.4 Design of Excitation Controller

Excitation controller is an important part of synchronous generator. Its main role is to maintain the stability of generator terminal voltage and maintain the balance of reactive power. The excitation controller can sample the voltage of the synchronous generator pattern and compare with the reference voltage. It will automatically adjust the exciter voltage, excitation electrical and terminal voltage of generator. So, it can meet the requirements of stable operation for the system.

The excitation regulation system of VSG can be realized by referring to the principle of excitation control system of the synchronous generator. Its control block diagram is shown in the Fig 6.

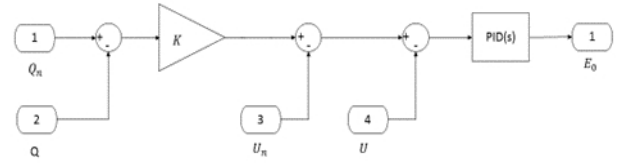

Fig 6 Excitation controller.

$U_n$  is the rated voltage of VSG.  $U$  is the actual voltage output value.  $Q_n$  is the rated reactive power of VSG. And  $Q$  is the actual reactive power of VSG. The PID regulating module is used to regulate  $E_0$  which is no load excitation EMF. When the reactive load changes suddenly, the system operates at a new voltage level by the regulation of the excitation controller.

### 3. STABILITY ANALYSIS

As shown in the **Error! Reference source not found.**:

$$\left( \frac{\omega_n}{2\pi} - \frac{\omega}{2\pi} \right) * \left( K_p + \frac{K_I}{S} + K_D S \right) + P_n = P_t \quad (7)$$

$$\frac{P_t - P_e}{\omega_n} * \frac{1}{J} * \frac{1}{S} + \omega_n = \omega \quad (8)$$

$$\frac{\left( K_p + \frac{K_I}{S} + K_D S \right) (\omega_n - \omega)}{2\pi} + P_n - P_e + \omega_n = \omega \quad (9)$$

$$\frac{\left( K_p + \frac{K_I}{S} + K_D S \right) (\omega_n - \omega)}{2\pi} + P_n - P_e + \omega_n^2 J S = \omega \omega_n J S \quad (10)$$

$$\frac{\left( K_p + \frac{K_I}{S} + K_D S \right) (\omega_n - \omega)}{2\pi} + \omega_n^2 J S - \omega \omega_n J S = P_e - P_n \quad (11)$$

$$P_e - P_n = \frac{\left( K_p + \frac{K_I}{S} + K_D S \right) (\omega_n - \omega)}{2\pi} + \omega_n J S (\omega_n - \omega) \quad (12)$$

$$\begin{aligned} G_{close\ loop} &= \frac{\Delta \omega}{\Delta P} = \frac{1}{\frac{K_p + \frac{K_I}{S} + K_D S}{2\pi} + \omega_n J S} \\ &= \frac{2\pi}{K_p + \frac{K_I}{S} + K_D S + 2\pi \omega_n J S} \\ &= \frac{2\pi S}{K_p S + K_I + (K_D + 2\pi \omega_n J) S^2} \end{aligned}$$

(13)

When

$$P = 10000, I = 50000, D = 100$$

$$\omega_n = 2\pi f_n = 2\pi * 50 = 100\pi$$

Then

$$G_{close\ loop} = \frac{\Delta\omega}{\Delta P} = \frac{2\pi S}{(100 + 200\pi^2)S^2 + 10000S + 50000} \quad (14)$$

$$G_{open} = \frac{X}{1-X} = \frac{2\pi S}{(100 + 200\pi^2)S^2 + 10000S + 50000 - 2\pi S} \quad (15)$$

According to Rous stability criterion for a second order system, the system remains stable when all the coefficients of the closed-loop characteristic equation are positive.

The equation (16) is shown as the following according to the Laplace's final value theorem.

$$\lim_{t \rightarrow \infty} \Delta\omega(t) = \lim_{s \rightarrow \infty} sG_{P-\omega}(s) \frac{\Delta P(s)}{s} = 0 \quad (16)$$

The equation (16) shows that there is no static error in frequency response when the system reaches steady state.

#### 4. SIMULATION AND RESULT ANALYSIS

In order to verify the frequency and voltage regulation characteristics of TGS based on the enhanced VSG technology, a simulation model is designed. The simulation conditions are shown in Fig 7. In the case of isolated island working mode, the AC power system is supplied by the TGS alone. The initial value of the active load is 10kW. The active load suddenly reduces to 8KW at 1 second. At 2 second, the active load suddenly increases to 12KW.

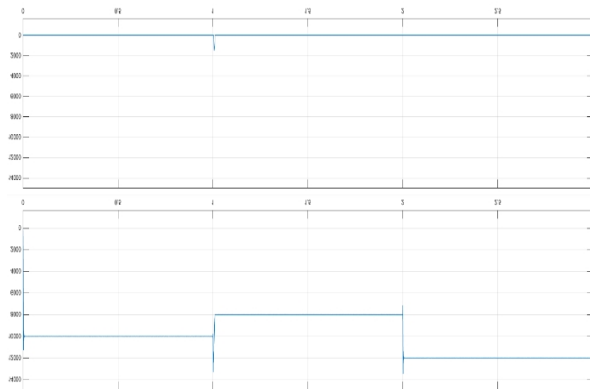

Fig 7 P and Q waveform.

Fig 8 is the P and f waveform based on the traditional VSG. And the Fig 9 is the P and f Waveform Based on the Enhanced VSG.

As shown in the Fig 8, the working load decreases and the frequency is stable at about 50.2HZ between 1 and 2 seconds. Between 2 and 3 seconds, the working load increases and the frequency is stable at about 49.8HZ. Under the traditional VSG mode, whether the working load increases or decreases, there is static deviation between the final frequency value and the standard frequency 50HZ.

As shown in Fig 9, the working load is reduced between 1 and 2 seconds. And the frequency is finally stabilized at 50HZ after a short period of adjustment. The load increases between 2 and 3 seconds, and the frequency stabilizes at 50HZ after a short period of adjustment. Therefore, the final frequency of the system does not change according to the load when the system is working in the enhanced VSG mode. The final frequency value always works steadily at the standard frequency of 50HZ.

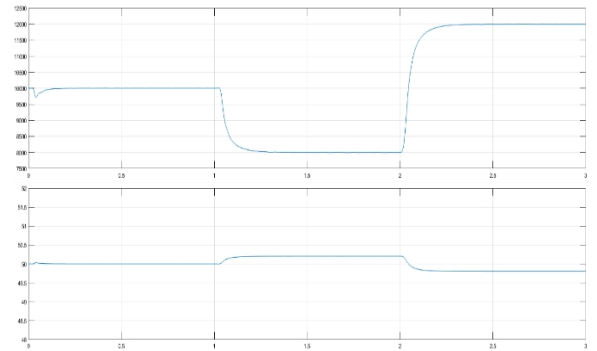

Fig 8 P and f waveform based on traditional VSG.

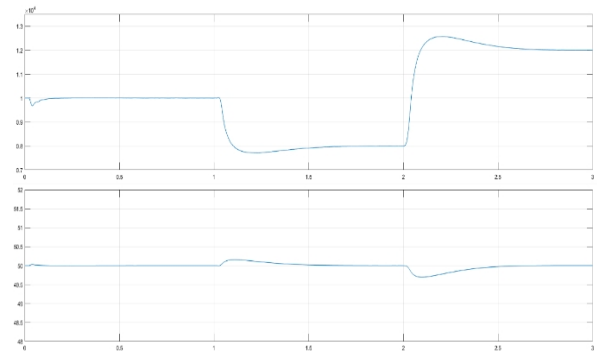

Fig 9 P and f waveform based on the enhanced VSG.

Fig 10 U and I waveform Fig 11 and Fig 12 are the U and I waveform. As shown in the Fig 10, the voltage value can remain stable whether the working load is reduced

at 1 second or increased at 2 second. The current value changes according to the working load increases or decreases.

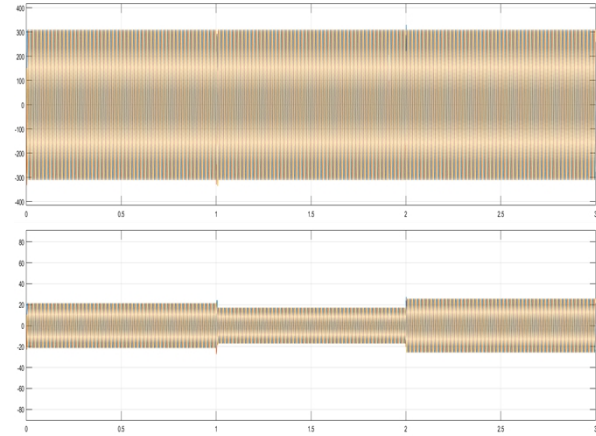

Fig 10 U and I waveform.

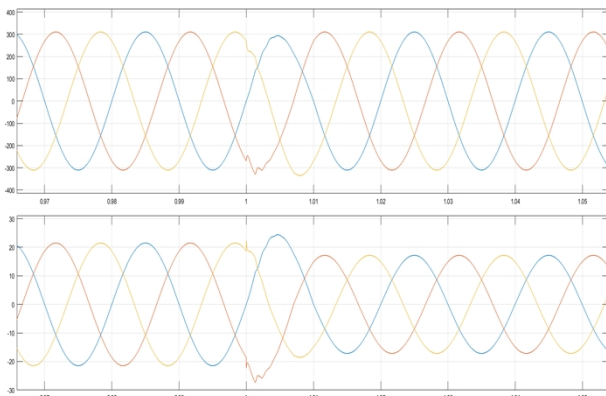

Fig 11 U and I waveform at around 1 s.

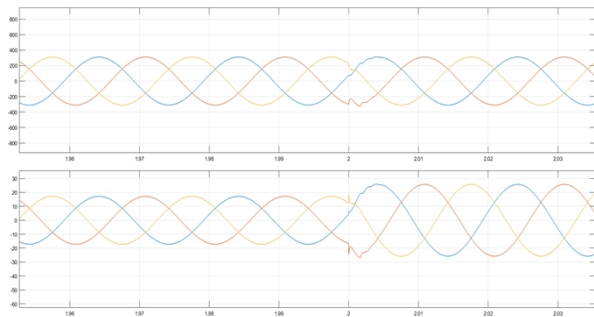

Fig 12 U and I waveform at around 2 s.

## 5. CONCLUSIONS

When the distributed power system is working on the grid-on mode, its frequency and voltage can be

supported by the electric grid. When the distributed power system is working on the grid-off mode, TGS need to maintain its frequency and voltage be in a stable value.

The VSG technology can be applied to possess the rotational inertia by simulating synchronous generator. The TGS with VSG operation mechanism facilitates the frequency and voltage regulation. The traditional VSG is mainly based on the droop feature and can realize primary frequency modulation when the working load changes. The disadvantage of this method is that the final frequency will have a static bias. An enhanced VSG control strategy is proposed in this paper. The schematic diagram and control algorithm model of enhanced VSG are described in details. The power and frequency controller and excitation controller have been designed. The stability of the system under different conditions has been analyzed.

A simulation model is designed to verify the frequency and voltage regulation characteristics of TGS. The distributed power system which is working on the isolated island is supplied by the TGS alone. It simulates the active load suddenly reduces or increases at different times. Comparing with the traditional VSG, there is no static deviation between the final frequency value and the standard frequency 50HZ.

The simulation results show that the enhanced VSG can simulate the role of the synchronous generator in the traditional power system. It can adjust the frequency and voltage reasonably and adjust the output in time when the working load fluctuates which is beneficial to the stable operation of the system.

## REFERENCE

- [1] J. Rocabert, A. Luna, F. Blaabjerg, X. Rodri, and P. Guez, "Control of power converters in AC microgrids," IEEE Trans. Power Electron., vol. 27, pp. 4734–4749, 2012.
- [2] Balaguer I J, Lei Q, Yang S, et al. Control for Grid-Connected and Intentional Islanding Operations of Distributed Power Generation [J]. IEEE Transactions on Industrial Electronics, 2011, 58(1): 147-157.
- [3] P. Sreekala, D. A. Ramkumar and D. K. Rajesh, "Enhanced Performance of Thermoelectric Generator by Modified H-Bridge Converter," 2019 IEEE International Conference on Intelligent Techniques in Control, Optimization and Signal Processing (INCOS), Tamilnadu, India, 2019, pp. 1-5.
- [4] K. Hwu, Y. Yau and M. Hsieh, "Thermoelectric Energy Conversion System With Multiple Inputs," in IEEE

Transactions on Power Electronics, vol. 35, no. 2, pp. 1603-1621, Feb. 2020.

[5] A. Ulbig, T. S. Borsche, and G. Andersson, "Impact of low rotational inertia on power system stability and operation," IFAC Proceedings Volumes, vol. 47, no. 3, pp. 7290–7297, 2014.

[6] M. Dreidy, H. Mokhlis, and S. Mekhilef, "Inertia response and frequency control techniques for renewable energy sources: A review," Renewable and Sustainable Energy Reviews, vol. 69, pp. 144 – 155, 2017.